

SHADOW SURFACES AND SPINES OF 3- AND 4-MANIFOLDS: LECTURE NOTES FROM A SEMINAR IN PISA, ITALY

DYLAN P. THURSTON

1. WORKING WITH SHADOWS AND KNOTTED TRIVALENT GRAPHS

1.1. Using shadows to understand KTG operations. Shadows are a good way to understand sequences of KTG operations, and sequences of KTG operations are good ways to figure out which 3- or 4-manifold a given shadow represents. To see this more clearly, let's review some of the definitions and basic results from previous lectures, filling in gaps as we go to make the connections more explicit.

Definition 1. A *shadow surface* is a connected simple surface with gleams (in \mathbb{Z} or $\mathbb{Z} + \frac{1}{2}$, as appropriate) associated to each face.

Definition 2. A shadow Σ^2 , with boundary Γ , *represents* (M^3, K) , where K is a (framed) knotted embedding of Γ in M^3 , if there is a 4-manifold W^4 , $\partial W^4 = M^3$, and a smooth proper embedding of Σ in W , so that

- $\partial\Sigma$ maps to the spine of K ;
- The gleams on the regions of Σ match those obtained from the relative Euler number of the normal bundle to Σ in W ; and
- W is a regular neighborhood of Σ .

Some points to note:

- Every shadow represents a unique (M, Γ) pair (and the W in the construction is unique).
- If Σ is collapsible, then $M^3 = S^3$ and $W^4 = B^4$, since the collapse can be extended to the regular neighborhood of Σ . Note that this is independent of the gleams on the regions of Σ !
- Every knotted graph K in S^3 can be obtained from an appropriate collapsible Σ .

Now let's see how to use shadows as operations.

Definition 3. A shadow Σ with boundary split into components $\partial\Sigma = \Gamma_0 \cup \Gamma_1 \cup \dots \cup \Gamma_k$ is *collapsible relative to* $\Gamma_1, \dots, \Gamma_k$ if the surface

$$\bigcup_{i=1}^k \text{Cone}(\Gamma_i) \cup_{\Gamma_i} \Sigma$$

is collapsible.

Such a Σ will also be called a *shadow operation*, for the following reason:

Definition/Proposition 4. Let Σ be a shadow collapsible relative to $\Gamma_1, \dots, \Gamma_k$ and let K_1, \dots, K_k , respectively be knotted embeddings of $\Gamma_1, \dots, \Gamma_k$ in S^3 . Let X be B^4 with k smaller balls removed, with one of the K_i 's embedded on the boundary of each removed ball. Then there is a unique knotted K_0 in the outer S^3 boundary of X so that there is a smooth proper embedding of Σ in X so that:

Date: June 18, 2003.







Name	Operation	Movie surface
Unzip		
Bubbling		
Connect sum		
Unknot		
Möbius band		
Tetrahedron		

TABLE 1. The surface created from a movie of each knotted trivalent graph operations and generators. The surfaces depicted all lie in a local 3-dimensional slice of a 4-dimensional space; although the pictures appear 3-dimensional, they are really pictures of surfaces in 4 dimensions.

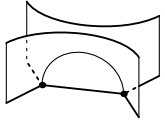
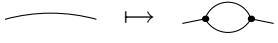
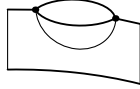
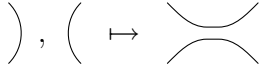
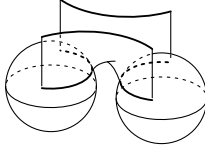
- Each Γ_i in the boundary of Σ maps to the spine of the corresponding K_i ;
- The gleams on the regions agree with the normal bundle; and
- $\Sigma \cup \bigcup_i S_i^3$ is a spine for X .

This K_0 is said to be the result of *applying* the shadow operation Σ to K_1, \dots, K_k .

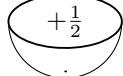
Note that K_0 can be constructed by taking a collapsible shadow Σ_i for each of the K_i and gluing each Σ_i to the appropriate boundary of Σ ; the resulting big shadow will be collapsible, by the definition of relative collapsibility.

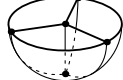
We can define the *composition* of two shadow operations in the evident way, by attaching the output graph of one shadow operation to one of the inputs of another.

Example 5. For any framed trivalent graph Γ , the surface $\Gamma \times [0, 1]$ (with input $\Gamma_1 = \Gamma \times \{1\}$ and output $\Gamma_0 = \Gamma \times \{0\}$) represents the identity operation on embedded copies of Γ .

Example 6. A disk with two holes (with the boundaries of the holes S_1^1, S_2^1 as input and the outer boundary S_0^1 as output) represents the connected sum operation on knots. We can find a separating sphere dividing the two components by looking at the fiber over a curve running from S_0^1 to itself separating the other two boundaries from each other.

More generally, it is straightforward to check that the elementary KTG operations are represented by the corresponding movie surface, recalled for convenience in Table 1.

The following propositions assure us that the correspondence between KTG operations and collapsible shadows is really right.

Proposition 7. *Every collapsible shadow can be built by stacking a sequence of movie surfaces (including the generators, the Möbius band and the tetrahedron).*

Proposition 8. *Every relatively collapsible shadow with no vertices can be built from stacking movie surfaces (not including the generators).*

The following definition gives a partial answer to the earlier question of which sequences of KTG operations are “trivially the same” (independent of relations on the generators).

Definition 9. Two sequences of KTG operations are *shadow equivalent* if they yield the same shadow surface.

This is nearly the same as defining two sequences of operations (not including generators) to be the same if they have the same effect on all input tuples of KTGs.

Finally, to go outside the domain of collapsible shadows, we have the following easy proposition.

Proposition 10. *Let Σ be a shadow surface with a circle boundary component C , representing $(M^3, K \cup K')$, where K is the circle corresponding to the boundary component C . Then $\Sigma \cup_C D^2$ is a shadow representing the surgered 3-manifold (M_K, K') .*

1.2. Using KTG operations to understand shadows. It can be quite difficult, in general, to see which 3-manifold a given shadow represents; it is usually much easier to see what the result of a given sequence of KTG operations is. We can use the relationship above to help us out.

Example 11. (A shadow for the Hopf link; pictures not yet drawn)

Note that in Example 11 above, you can see that the two components are each 0-framed and have linking number 1 with each other using the following:

Proposition 12. *Let Σ be a shadow, and let $\Sigma_1, \Sigma_2 \subset \Sigma$ be oriented subsurfaces (without singularities). Then*

$$i(\Sigma_1, \Sigma_2) = \sum_{F \in \Sigma_1 \cap \Sigma_2} \text{gleam}(F) \text{mult}(\Sigma_1, F) \text{mult}(\Sigma_2, F)$$

where the sum runs over all faces in the intersection and *mult* means the algebraic multiplicity (with signs).

Example 13. Consider a simple vertex, as on the left below. If we consider this (4-dimensionally) to be attaching the lower region along a curve, it is natural to ask what happens if we homotop the curve so that it runs across the upper region, as on the right.

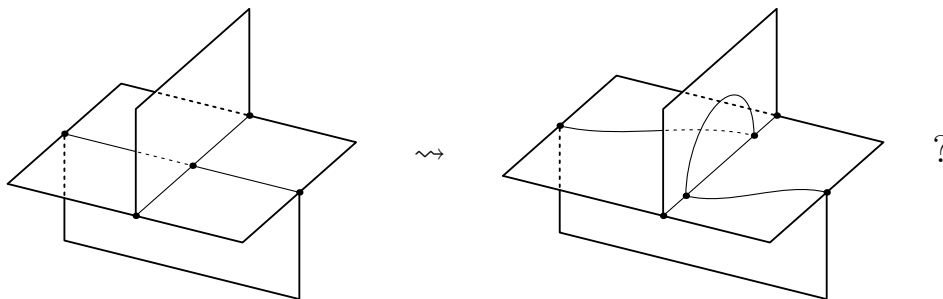

But what gleams should we assign to the regions? A little thought shows that the central region has a boundary twisted like a Möbius strip, so the gleam must be in $\mathbb{Z} + \frac{1}{2}$. Let’s

try assigning a gleam of $-\frac{1}{2}$: what is the KTG corresponding to the shadow below?

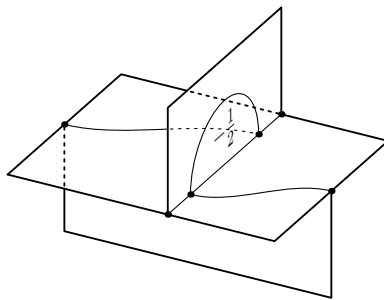

(The sequence of operations is not yet drawn.) We end up with an unknotted tetrahedron with some twisted edges. It's a simple exercise to figure out the correct compensatory twists; in the end, we find that

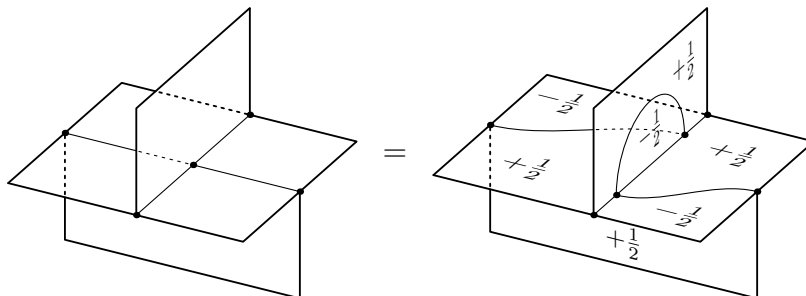

1.3. Shadow calculi. So far, we've seen two relations between different shadow representatives of the same KTG (or knot or 3-manifold or 4-manifold): the pentagon or 2-3 move (from the first lecture) and the hexagon (from Example refexamp:hexagon). There is one more we always need: the 2-0 move. Are there any more? For some purposes, the answer is "no":

Theorem 1. ¹(Collapsible calculus) *Any two collapsible shadows Σ_1, Σ_2 with at least one vertex for the same KTG K can be related by a sequence of pentagon, hexagon, and 2-0 moves (restricted to only pass through collapsible shadows).*

The proof proceeds by showing that (if there are sufficient vertices)

- Every collapsible shadow is equivalent modulo these moves to one constructed from a planar diagram of K .
- Any Reidemeister move on a planar diagram can be achieved with a sequence of these moves.

The hypothesis that Σ_i has at least one vertex can be removed by adding two additional moves. (Pictures to be drawn.)

What about for a 3-manifold M ? Do these two moves suffice to relate any two shadows of M ? No, since the 4-manifold W appearing as the regular neighborhood of M is unchanged by the two moves. Let us add another move, the ± 1 bubble move:

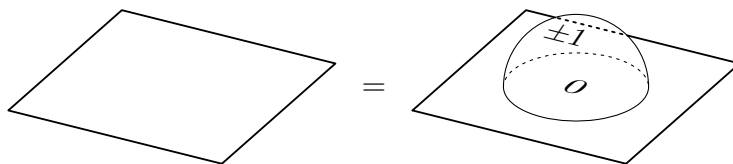

¹Some combination of me and Francesco Costantatino proved each of the following theorems some time ago, but we have not yet finished writing the results down and there remains some possibility of a small error.

From various points of view, this can be seen to be the same as the connect sum of W^4 with $\mathbb{C}P^2$ or $\bar{\mathbb{C}P}^2$, the Kirby I move, or the Fenn-Rourke move. In any case (using the Kirby calculus) we have the following theorem.

Theorem 2. *Any two simply-connected shadows Σ_1, Σ_2 representing the same (M^3, K) can be related by a sequence of pentagon, hexagon, 2-0, and ± 1 bubble moves.*

What if we want preserve the 4-manifold?

Question 14. (Embedded Andrews-Curtis) Are the pentagon, hexagon, and 2-0 moves enough to relate any two shadows whose thickenings are the same 4-manifold?

The answer to this question is likely to be very difficult, as we can see from the following conjecture related to the special case when the shadow is contractible (not collapsible):

Conjecture 15. (Andrews-Curtis) *Any two contractible simple 2-polyhedra can be related by a sequence of pentagon, hexagon, and 2-0 moves, ignoring the gleams.*

This conjecture is usually stated algebraically, in terms of balanced presentations for the trivial group, but this is an equivalent form. The conjecture is generally believed to be false.

Note that the 4-manifolds constructed by thickening a shadow are always made of 0-, 1-, and 2-handles. One might hope for a better characterization of this class of 4-manifolds. It is easy to see that for such a W^4 , ∂W is connected and the map $\pi_1(\partial W) \rightarrow \pi_1(W) = \pi_1(\Sigma)$ is surjective. (Turaev called such a 4-manifold *slim*.)

Question 16. Can every slim 4-manifold be constructed with only 0-, 1-, and 2-handles?

Even the case when $\pi_1(W)$ is trivial is interesting.

There is another notion, of shadows for closed 4-manifolds: if the 3-manifold M^3 constructed from a shadow happens to be a connected sum of $S^1 \times S^2$'s, then we can attach 3- and 4-handles to complete the thickening of the shadow to construct a closed 4-manifold. In this context, we can see that a 0 bubble move (analogous to the ± 1 bubble moves above) is the same as attaching a 2-handle and cancelling 3-handle.

Theorem 3. (Turaev) *Any two shadows for the same closed 4-manifold can be related by the pentagon, hexagon, 2-0, and 0 bubble moves.*

Again, the freedom to attach extra bubbles (increasing the second homology of the surface) lets us get around the Andrews-Curtis problem.

DEPARTMENT OF MATHEMATICS, HARVARD UNIVERSITY, CAMBRIDGE, MA 02138, USA
E-mail address: dpt@math.harvard.edu